

# Design and analysis of a new type of twin screw extruder

JIANHUA REN<sup>1,2</sup>, XINYI LIU<sup>1</sup>, JUNJIE ZHAO<sup>1</sup>

**Abstract.** The twin screw extruders are widely used. However, to ensure the special requirements, a new type twin screw extruder with three-step is independent developed. There are advantages of good compression effect and uniform mixing. In this paper, we analyze the four gaps of meshing twin screw extruder, and introduces the overall scheme design, the structural layout design, the determination of main parameters, and the screw mechanism design of the three-step twin screw extruder. It is designed as deep channel and coarse-pitch thread in the feeding section. And in the compression section, the pitch is changed from large to small by changing the pitch in each segment and the compression effect is improved. Based on solid model of Pro/E, ANSYS software is applied to carry out the three kinds of finite element analysis of screw— the static analysis, the modal analysis and the harmonic response analysis.

**Key words.** Three-step twin screw extruder, finite element analysis, finite element analysis, vibration mode.

## 1. Introduction

The twin screw extruder has been widely used in polymer processing industry since its inception in 1935[1]. The material is divided into type C cells by two screw kneading conjugate lines, with the rotary screw, the material is forced to move forward with the intermeshing threads in twin screw extruder [2,3]. To satisfy the requirements of the diversified and complex engineering material products in its consistent development, it is necessary to develop the twin screw extruder with high-performance, it adapts to the requirements of many kinds of small batch material modification, and it must be combined with improving the engineering practical production and productivity, which requires the twin screw extruder must meet the suitable residence time and high shear force. In recent years, manufacturers have launched some new twin screw extruders.

In the common twin screw extruder, the barrel of parallel twin screw extruder is

---

<sup>1</sup>Workshop 1 - Mechanical and Equipment Engineering Institute Hebei University of Engineering, Handan, China

<sup>2</sup>Corresponding author: Jianhua Ren; e-mail: 799064289@qq.com

equal diameter. It is difficult to achieve the larger compression of the fluffy material. The conical twin screw extruder has good compression effect, but the mixed effect is bad, the kneading strength cannot be adjusted. To achieve the compression and mixing of the material at the same time, and according to the actual requirement to adjust the compression ratio and the degree of mixing a new type of extruder—three-step twin screw extruder, which is suitable for weight gain granulation of Methyl Cellulose, was designed in this paper by the modern design methods and techniques [1,4].

## 2. Four gaps of meshing twin screw

There are four gaps in the meshing twin screw extruder: These gaps indicate the mutual position of the meshing twin screw, material is filled in the gaps, and the position and size of gaps determine the force of the screw.

$\delta_f$  is the gap between the flight tip and the barrel wall (namely flight gap).  $\delta_c$  is the radial gap (namely rolling gap).  $\delta_t$  is the tetrahedral gap,  $\psi$  is the angle between the bottom of channel and the side of flight.  $\delta_s$  is the side gap.

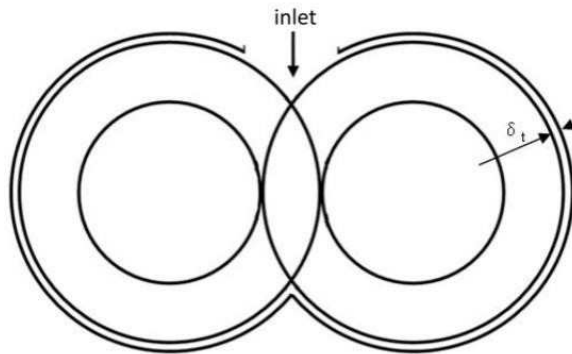

Fig. 1. Flight gap

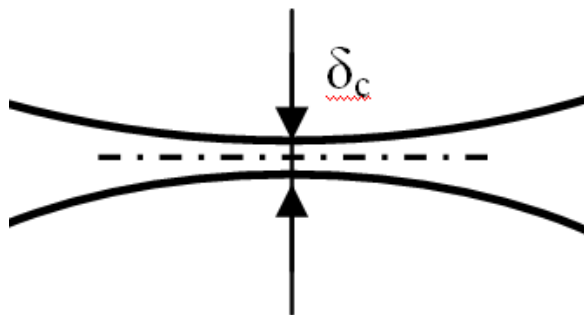

Fig. 2. Radial gap

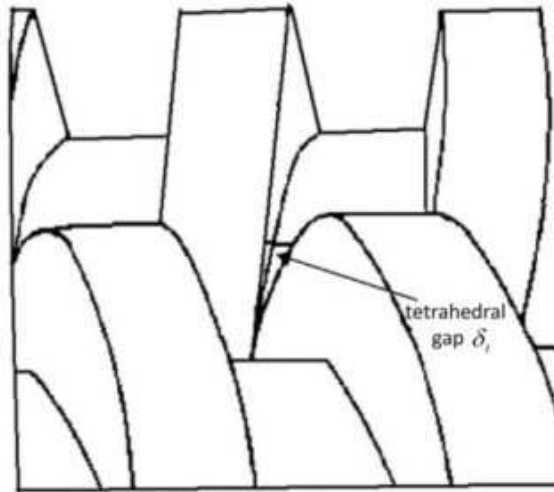

Fig. 3. Tetrahedral gap

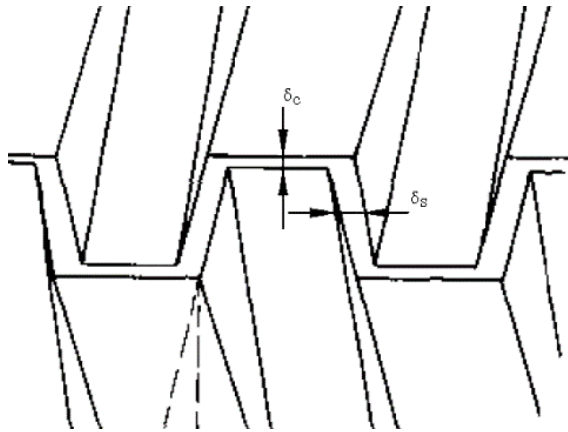

Fig. 4. Side gap

### 3. The overall design of three-step twin screw extruder

According to the relevant theory of mechanical design and meshing theory, the twin screw extruder is designed in detail, and acquiring relevant design parameters by calculation. The main structure parameters are as follows:

#### 1. Screw

Diameter: 196/186/176 Aspect ratio: 15/1 Rotation: co-rotating dextrorotation speed: 100r.p.m Torque of each screw: 30000 NM Meshing center distance: 150 mm

#### 1. Barrel

Length of Barrel: Charge Section: 730mm. Discharge Section: 950mm. The barrel with charge opening: A barrel with discharge opening: A form of barrel: For cleaning of screw conveniently, it uses Harvard architecture. The overall arrangement of stepped twin screw extruder, as shown in Figure 5:

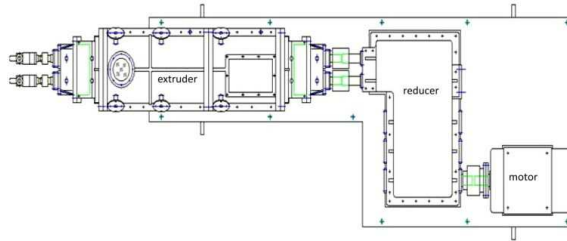

Fig. 5. The overall arrangement of three-step twin screw extruder

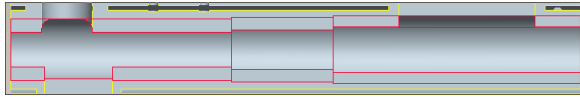

Fig. 6. The structure of barrel



Fig. 7. The pattern of screw

## 4. The structural design of screw

200/190/180 The three-step twin screw extruder is a specially designed twin screw extruder. It has the following features: The feeding section has the deep channel, coarse-pitch thread, which is suitable for the fluffy fibrous material. The compression section has the minor diameter, fine pitch thread. The various screw blocks are modular construction. It can be assembled according to the needs and adjust to the intensity of kneading.

After calculation, the three-dimensional solid models of the core shaft and each thread element are as drawn in Figure 7. Finally, it is assembled in an integral for forming screw.

## 5. The finite element analysis

### 5.1. ANSYS software

Therefore, ANSYS software is widely applied in all the fields of national production[5,6]. This section focuses on the utilization by the technology of CAD (Computer aided Design) combined with CAE (Computer aided Design Engineering), solid model of twin screw extruder is set up by using Pro/E software, and the screws of the new type of three-step co-rotating twin screw extruder, including the core shaft and thread element are analyzed by the finite element method with professional finite element analysis software of ANSYS in CAE, to investigate the loaded stress and the condition of strain and improve its structure parameters, sequentially it achieves the optimum design of structure[7].

### 5.2. Static analysis

Structural statics analysis is applied to analyze the displacement, stress, strain and force caused by the systems or components in given load and without considering the impact of inertia and damping. In this project, the analysis of twin screw is initiated by ANSYS software.

(1) Pretreatment, creating the finite element model of structural static analysis

The created solid model into ANSYS through interfaces of Pro/E and ANSYS, as shown in Figure 8. The definition of element type, material properties and meshing

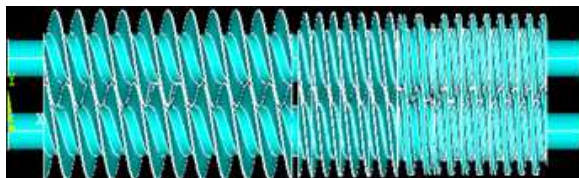

Fig. 8. The solid model of twin screw

When the material of parts is certain, on this basis, we can establish the finite element model, the solver searches the related characteristics of each material in the



Fig. 9. Division of mesh

operational analysis. Every material has different material characteristics, a lot of characteristics are characterized by numerical. In the screw, we select the material of screw shaft is 20CrMnTi, the material of thread block is 42CrMo. The main performance indexes of the two kinds of metallic materials are as follows:

Table 1.Parameter of metallic material

	Density??kg/m <sup>3</sup> ??	Elastic Modulus??MPa??	Poisson Ratio
20CrMnTi	7820	204e+3	0.3
42CrMo	7850	206 e+3	0.3

Currently, there are three kinds of mesh method, named free meshing, mapped meshing and sweep meshing of volume. Free meshing aims at the complicated shape of surface and volume to mesh, the element shape and any pattern are unrestricted; mapped meshing is mainly applicable to the model of regular surface and volume, such as quadrilateral element and hexahedron, due to the row of unit and the obvious regular shape. The volume mesh is generated by using the sweep meshing of volume, based on the different source mesh, the volume will generate the unit of different shapes, swept mesh and the volume are closely related, it can get the swept mesh by sweeping the volume .

This paper adopts method of free meshing to acquire the model of finite element, as shown in Figure 9.

Applying loads and solving

Based on the theory of solid conveying, proposed by Darnel and Mol, the material contacts with the barrel of surface, the bottom of channel and the side of thread. The material is propelled by the rotating screw, and displacement constrains are applied to the two support ends of screw.

Because of the movement of material in the barrel, it is acted upon by eight forces, as shown in Figure 10. Among these forces:

- F1: The friction caused by the surface of barrel on material;
- F2, F6: The pressure caused by the pressure growth on material;
- F3, F4: The friction caused by the side of flight on material;
- F5: The friction caused by the bottom of channel on material;
- F7, F8: The friction caused by the side of flight.

The loads of screw are added by action and reaction principle, as shown in Figure 11.

(1)Solving the static solution

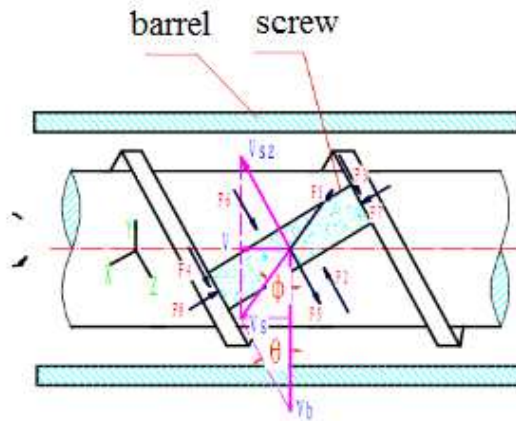

Fig. 10. The force acted on materials

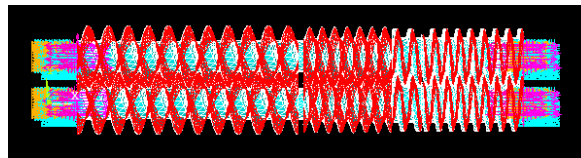

Fig. 11. Loading weight and constraint of model

(2)After treatment, checking the results

After completing the solution, entering the post-processing modules and displaying structural deformation pattern, then obtaining the patterns of before and after deformation, as shown in Figure 12. And there is significance for analyzing performance of the extruder, the deformations on each direction are obtained by analyzing. Checking the contours of displacement, as shown in Figure 13.

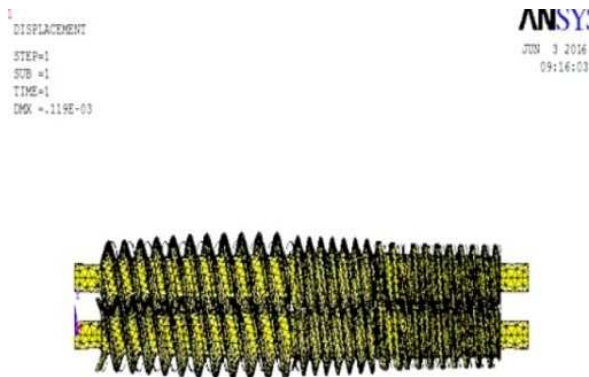

Fig. 12. Deformation pattern of structure

The contour chart of stress, as shown in Figure 14:

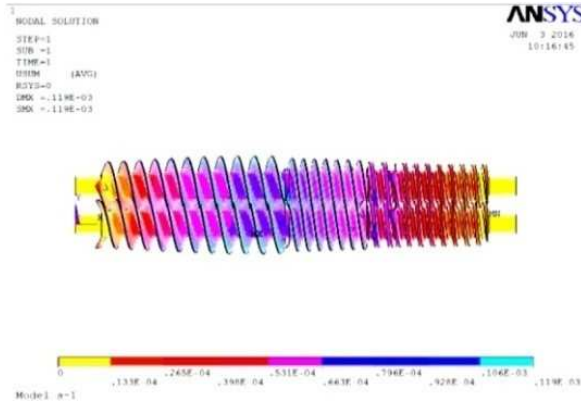

Fig. 13. Displacement pattern of model

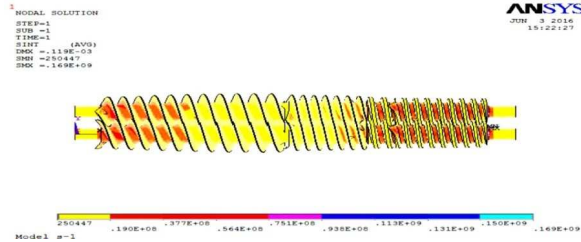

Fig. 14. Geometry of considered trapezoidal plate

### 5.3. Modal analysis

In the design of bear dynamic loads of parts or components, if you want to determine that the natural frequency and vibration mode of this component, it is necessary to carry out modal analysis (the calculating modal analysis and the experimental modal analysis). It can accurately simulate the different step of the modal characteristics of the force-bearing component on a frequency or a frequency domain by modal analysis, while the different step characteristics are mastered, meaning it can make prejudgments to the effects of bearing parts with various vibration source in this frequency or a frequency domain inside and outside.

There are important application values on fault diagnosis, meanwhile, there are positive meanings for accident prevention and increasing the life of components.

The modal analysis of ANSYS software can carry out modal analysis and modal analysis of circularly symmetric structures for the pre-stress structure, the former has the modal analysis of rotating blade and so on, the latter permits to set up a part of model of circularly symmetric structures to complete the modal analysis of the whole structure.

#### (1)Creating the finite element model

The established method of finite element is substantially similar in ANSYS, and this modal analysis model is same as the model of static analysis, the finite element model of static analysis is directly introduced into ANSYS.



(2)Owing to the screw shafts affiliation to the rigid body with entity, therefore, the model can be extracted with Block Lanczos, setting the ten-step model is extracted, a total four surfaces— both ends of cylindrical surfaces of twin screw are selected, then bear boundary condition and solving.

(3) Output the calculation

The ten steps model of output model. By the modal frequency pattern, it is suggested that the first-step natural frequency of two screw is 186.18HZ.

Table 2. Index of data sets on results file

SET	TIME/FREQ	LOAD STEP	SUBSTEP	CUMULATIVE
1	186.18	1	1	1
2	186.23	1	2	2
3	186.62	1	3	3
4	186.86	1	4	4
5	499.52	1	5	5
6	499.64	1	6	6
7	500.26	1	7	7
8	500.49	1	8	8
9	774.24	1	9	9
10	774.42	1	10	10

(4)The output of each step vibration mode, the first-step vibration mode, as shown in Figure 15.

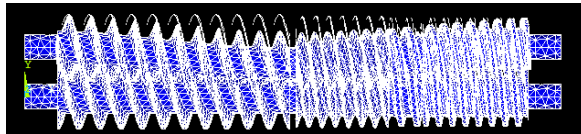

Fig. 15. The first-step vibration mode

## 6. Conclusion

The finite element analysis and meshing are processed by building the solid models, and imposing constraint on the screw that is based on the analysis of load in screw, this can acquire displacement pattern of model and pattern of equivalent stress. The first-step vibration mode is drawn by the modal analysis of screw. Then we carried on the harmonic response analysis to analyze the modal displacement and process pattern of the three stages. Above all, the feasibility of three-step structure is proved.

## References

- [1] Z. G. XIAO: *Twin Screw Extruder and its Application*. Beijing:China Light Industry Press (2010).
- [2] A. EITZLMAYR, G. KOSCHER, G. REYNOLDS, Z. HUANG: *Booth J.Mechanistic modeling of modular co-rotating twin-screw extruders*. International Journal of Pharmaceutics 474 (2014), Nos. 1-2, 157-176.
- [3] H. C. SHI, Q. M. XIU, Z. G. XIAO: *3S Fluid Simulation of NI-MPE in Co-Rotating Twin Screw Extruder*. China Plastics Industry 16 (2012), No. 10, 79-83.
- [4] L. HUI, T. MICHAEL, D. KEVIN: *Progression of wet granulation in a twin screw extruder comparing two binder delivery methods*. AIChE Journal 61 (2015), No. 3, 780-791.
- [5] B. F. ZHU: *The Finite Element Method Theory and Application*. Beijing: China Water Resources and Hydropower Publishing House (2009), 5-10.
- [6] X. H. GAO: *A Concise Course of the Finite Element Method*. Beijing: Chemistry Industry Press (2014) 117-130.
- [7] A. ODAY, A. WASSAN, A. ABDULLAH: *Finite Element Analysis of Transient Thermoelastic Behavior in Multi-Disc Clutches*. Sae Technical Papers (2015).

Received November 16, 2016